

# High Pressure Diffuser

AIRBORNE PARTICLE COUNTER ACCESSORY



**Ported**



**Vented**

## Operating Manual

**This Page Intentionally Left Blank.**

Lighthouse Worldwide Solutions

# Isokinetic High Pressure Diffuser

Airborne Particle Counter Accessory



Ported High Pressure Diffuser



Vented High Pressure Diffuser

Operating Manual

**Copyright ©2019** by Lighthouse Worldwide Solutions. All rights reserved. No part of this document may be reproduced by any means except as permitted in writing by Lighthouse Worldwide Solutions. The information contained herein constitutes valuable trade secrets of Lighthouse Worldwide Solutions. You are not permitted to disclose or allow to be disclosed such information except as permitted in writing by Lighthouse Worldwide Solutions. The information contained herein is subject to change without notice. Lighthouse Worldwide Solutions is not responsible for any damages arising out of your use of the High Pressure Diffuser. High Pressure Diffuser, LMS™, LMS Express™, LMS XChange™, are trademarks of Lighthouse Worldwide Solutions.

Manufactured by:  
Lighthouse Worldwide Solutions  
300 West Antelope Road  
White City, OR 97503

LWS Part Number: 248083215-1 R4

# Table of Contents

<b>1</b>	<b>Safety.....</b>	<b>2</b>
	General Safety.....	2
	Caution Label .....	2
	Precautions .....	2
	Operational Safety .....	4
	Servicing Safety .....	4
<b>2</b>	<b>Introduction .....</b>	<b>5</b>
	Overview .....	5
	Vented High Pressure Diffuser.....	6
	Ported High Pressure Diffuser .....	7
<b>3</b>	<b>Unpacking, Inspecting, and Installing .....</b>	<b>9</b>
	Initial Inspection.....	9
	Installation .....	11
	Connecting the Diffuser .....	14
<b>4</b>	<b>Maintenance .....</b>	<b>15</b>



# 1 Safety

## General Safety

Warnings and cautions are used throughout this manual and the reader should become familiar with the meaning of a warning before operating the Diffuser. Most warnings will appear on the page with the subject or step to which it applies. Take care when performing any procedures preceded by or containing a warning.

## Caution Label

A Caution Label, as shown below, is attached to the body of the High Pressure Diffuser:

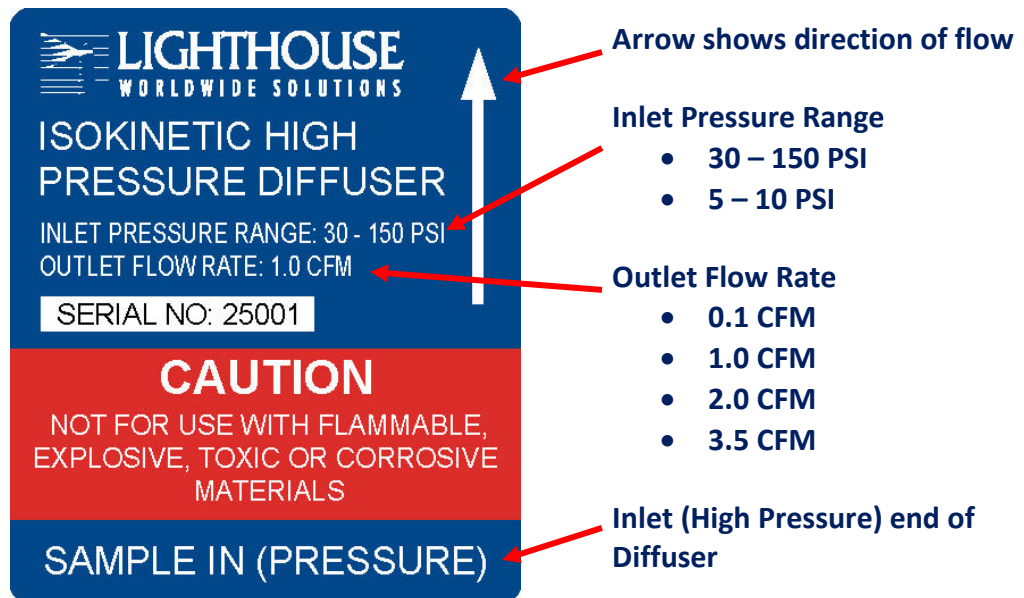

**Figure 1 Caution Label**

## Precautions

The Lighthouse Isokinetic High Pressure Diffuser is designed to provide safe, reliable operation. The following good practices will ensure the safety of both personnel and instrumentation:

1. Ensure that the high pressure source is turned off before installing or disconnecting the High Pressure Diffuser.
2. Be sure that the High Pressure Diffuser is installed so that air flows with the arrow. The end of the Diffuser marked **SAMPLE IN (PRESSURE)** must be connected to the high pressure source.
3. Ensure that all fittings, connectors, and adapters are tight (finger tight plus a 45° turn) before applying high pressure air to the inlet of the Diffuser.

## Operational Safety

**WARNING:** Do not block or plug the exhaust holes in the Vented version, nor plug the exhaust port on the Ported version of the High Pressure Diffuser. This action will pressurize the attached particle counting instrument and can result in extreme damage.

**WARNING:** Do not attempt to disassemble the High Pressure Diffuser while in operation. Remove the high pressure input from the inlet of the Diffuser before proceeding with adjustments.

## Servicing Safety

**WARNING:** Do not attempt to disassemble the High Pressure Diffuser while in operation. Remove the high pressure input from the inlet of the Diffuser before proceeding with any cleaning or parts replacement.

**WARNING:** This cleaning process detailed in this document involves the use of solvent and flux remover. Improper use of these materials can be hazardous to the user's health. Carefully read the Material Safety Data Sheet for precautions and guidelines for proper use.



## 2 Introduction

### Overview

The High Pressure Diffuser was designed for use with Lighthouse Airborne Particle Counters in applications where the sample is under pressure. Standard applications include sampling of CDA, CO<sub>2</sub>, Nitrogen lines, and other inert gases.

The Diffuser unit is available in a Vented or Ported version. The Vented version allows overpressure to vent into the test area, while the Ported version provides for connecting an exhaust line to route the overpressure to a desired location.

The Vented Diffuser comes in either a 0.1 CFM or 1.0 CFM model, while the Ported version has a 0.1 CFM, 1.0 CFM, 2.0 CFM, and 3.5 CFM model. Modifying the length of the Adjustment tube based on the input pressure allows the Diffuser unit to provide the proper flow output, providing accurate measurement capability regardless of the pressure of the sampled medium. See Chapter 3 in this manual for detailed instruction for adjusting the HPD for different input pressures.

The High Pressure Diffuser is compatible with the entire line of Lighthouse Solair, Remote, ApexP and ApexZ particle counters. When coupled with the proper accessory kit, the 0.1 CFM HPD works with the Handheld line of instruments as well.

- 402965281-1 (Accy: Handheld to HPD Plumbing) is needed when using the HPD with LWS Handheld particle counters.

## Vented High Pressure Diffuser

Three different versions of the High Pressure Diffuser are available in the Vented style:

HPD Model	LWS Part Number
0.1 CFM Vented HPD	402965230-1
1.0 CFM Vented HPD	402965230-2
1.0 CFM Vented HPD (ApexZ3 only)	402965230-5

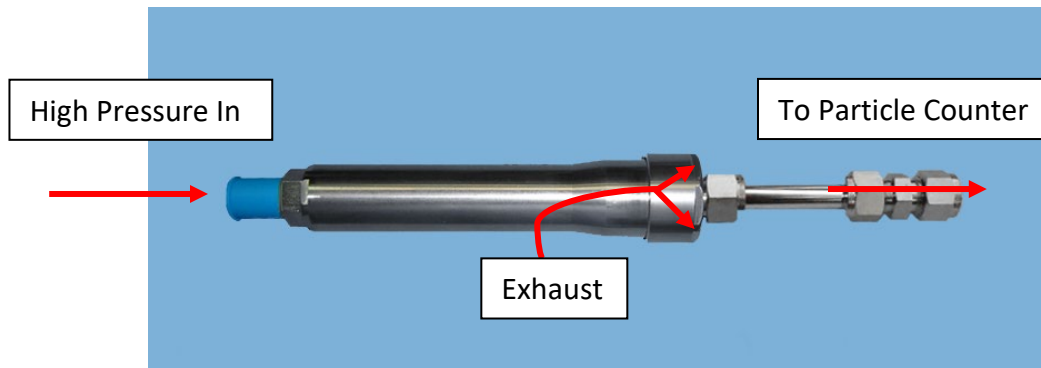

Figure 2-1 Vented HPD

<b>Material</b>	Stainless Steel
<b>Inlet Pressure Range</b>	5-10 PSI, 30-150 PSI, 70-150 PSI
<b>Outlet Flow Rate</b>	0.1 CFM or 1.0 CFM (depending on model)
<b>Flow Control</b>	Metal Orifice
<b>Isokinetic Sampling Port</b>	Adjustable
<b>Diffusable Mediums</b>	Pressurized Air, Nitrogen, CO <sub>2</sub> , and inert gases
<b>Inlet Port</b>	Inlet: 1/4" I.D. Metal Gasket, High Purity VCR Fitting
<b>Outlet Ports</b>	0.1 CFM: 1/8" I.D. Compression Fitting 1.0 CFM: 1/4" I.D. Compression Fitting 1.0 CFM (ApexZ3): 3/8" I.D. Compression Fitting
<b>Diameter</b>	1.31" [3.3 cm] at largest point
<b>Overall Length</b>	9.87" [25.1 cm] @ 150 PSI setting
<b>Weight</b>	1.11 lbs [0.5 kg]
<b>Cleanability</b>	The five parts can be disassembled and easily cleaned. The three standard O-rings can be replaced.

Table 2-1 Specifications: Vented High Pressure Diffuser

## Ported High Pressure Diffuser

Eight different versions of the High Pressure Diffuser are available in the Ported style, where overpressure exhaust can be routed to a desired location.

HPD Model	LWS Part Number
0.1 CFM Ported HPD	402965231-1
1.0 CFM Ported HPD	402965231-2
2.0 CFM Ported HPD	402965231-3
3.5 CFM Ported HPD	402965231-4
1.0 CFM Ported HPD (ApexZ3 Only)	402965231-5
3.5 CFM Ported HPD (ApexZ50 Only) 5-10 PSI Input Pressure	402965231-6
3.5 CFM Ported HPD (ApexZ50 Only) 30-70 PSI Input Pressure	402965231-7
3.5 CFM Ported HPD (ApexZ50 Only) 70-150 PSI Input Pressure	402965231-8

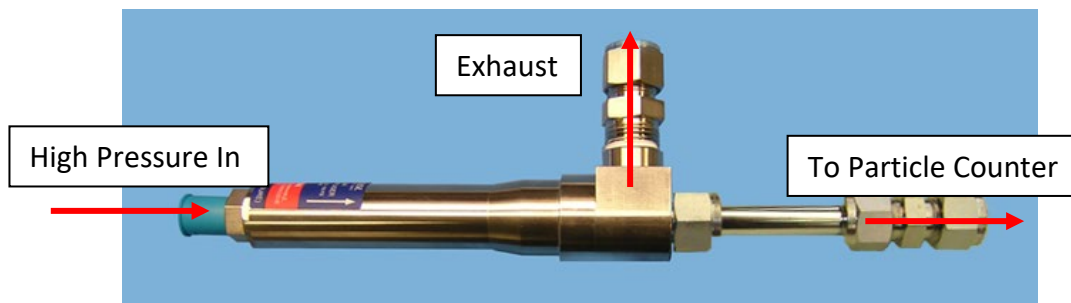

Figure 2-2 Ported HPD

<b>Material</b>	Stainless Steel
<b>Inlet Pressure Range</b>	5-10, 30-70, 70-150, or 30-150 PSI (depending on model)
<b>Outlet Flow Rate</b>	0.1, 1.0, 2.0, or 3.5 CFM (depending on model)
<b>Flow Control</b>	Metal Orifice
<b>Isokinetic Sampling Port</b>	Adjustable
<b>Diffusable Mediums</b>	Pressurized Air, Nitrogen, CO <sub>2</sub> , and inert gases
<b>Inlet Port</b>	Inlet: ¼" Metal Gasket, High Purity VCR Fitting
<b>Outlet Ports</b>	Outlet: 3/8" Compression Fitting 0.1 CFM: 1/8" I.D. Compression Fitting 1.0 CFM: 1/4" I.D. Compression Fitting 1.0 CFM (ApexZ3): 3/8" I.D. Compression Fitting 2.0 CFM: 3/8" I.D. Compression Fitting 3.5 CFM: 3/8" I.D. Compression Fitting 3.5 CFM (ApexZ50): 1/2" I.D. Compression Fitting
<b>Exhaust Port</b>	¾" O.D. Compression Fitting
<b>Size</b>	Width: 1.31" [3.3 cm] at largest point Height: 3.08" [7.8 cm]
<b>Overall Length</b>	9.87" [25.1 cm] @ 150 PSI setting
<b>Weight</b>	1.50 lbs [0.68 kg]
<b>Cleanability</b>	The six parts can be disassembled and easily cleaned. The three standard O-rings can be replaced.

**Table 2-2 Specifications: Ported High Pressure Diffuser**

# 3 Unpacking, Inspecting, and Installing

The Isokinetic High Pressure Diffuser has been thoroughly inspected and tested at the factory and is ready for use upon receipt, given no damage occurred in shipping.

## Initial Inspection

### Damage Inspection

Inspect the shipping carton for damage. If the container is damaged, notify the shipper immediately.

If the carton is undamaged, open it carefully and inspect the contents for broken parts, scratches, dents, or other visible damage. If any is apparent, record the type and extent of the damage on the Incoming Inspection form and inform the shipping company.

Photograph any damage noted for inclusion in reporting.

Report any damages to Lighthouse Technical Support at 1-800-945-5905 (USA) or at 1-541-770-5905 (outside of USA) before proceeding.

### Content Verification

Verify the contents of the package against the shipping list. If anything appears to be missing, contact your sales representative at Lighthouse immediately at 800-945-5905, or at [techsupport@golighthouse.com](mailto:techsupport@golighthouse.com).

Standard items included with each unit are:

1. Four Gasket Fittings
2. Read Me First
3. 10 ft. inlet hose

1

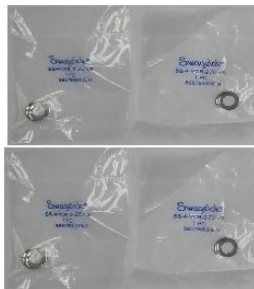

2



3



**To maintain the warranty, keep the undamaged shipping container and all packing material for reshipment of the instrument for calibration/cleaning/repair. Order replacement containers and packing materials only from Lighthouse, either directly or through an authorized distributor.**

Should it become necessary to return the unit to the factory for any reason, contact Lighthouse Customer Service or visit the website, [www.golighthouse.com/rma](http://www.golighthouse.com/rma), and obtain a Return Material Authorized (RMA) number. Reference this number on all shipping documentation and purchase orders. After receipt of the RMA number, follow the shipping instructions below:

1. Use the original container, caps, and packing materials whenever possible. Remove any attachments from the instrument.
2. If the original container and shipping materials are not available, wrap the unit in “bubble pack”, surround it with shock absorbent material, and place it in a double-wall carton. The instrument should be packed so that it does not rattle around when the container is vigorously shaken. Contact Lighthouse if a replacement shipping container is needed.

**Warning:** If the instrument is damaged during return shipping due to inadequate user packing, the warranty may be voided and additional repair charges may be due by the customer.

3. Seal the container or carton securely. Mark the container as “FRAGILE” and write the RMA number on any unmarked corner.
4. Return the instrument to the address provided by your Lighthouse representative or the RMA website.

## Installation

The installation of the High Pressure Diffuser has two major steps: Adjusting the air flow at the output of the Diffuser, and plumbing the device into the facility.

### Adjusting the Output for Isokinetic Sampling

Manipulation of the Adjustment Tube allows the user to obtain the proper air flow out of the Diffuser by correctly reducing the input High Pressure source. Figures 3-2 and 3-3 on the following pages detail the required length of the Adjustment Tube for proper flow rate out of the Diffuser based on the input pressure. Adjustment lengths are identical for all models. Figure 3-2 shows English measurements, while Figure 3-3 shows Metric measurements.

Adjustment Process:

1. Find your inlet pressure on the X-axis of the appropriate graph.
2. Trace a vertical line from the inlet pressure to the graphed Isokinetic Sampling curve.
3. At the intersection, trace a horizontal line to the left for the proper length for the adjustment tube from the Y-axis labels.
4. Loosen the Locking Cap so the Adjustment Tube length can be changed.

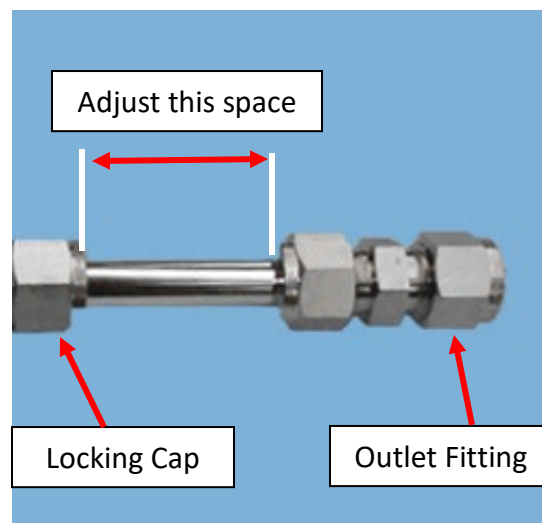

**Figure 3-1 Adjustment Tube**

5. Carefully adjust the length of the tube to match the measurement found in Step 3.
6. Tighten the Locking Cap, being careful not to change the length of the Adjustment Tube. Tighten the Cap finger tight, then use a wrench to tighten another 45°.
7. Check to ensure that the Adjustment Tube is the correct length.

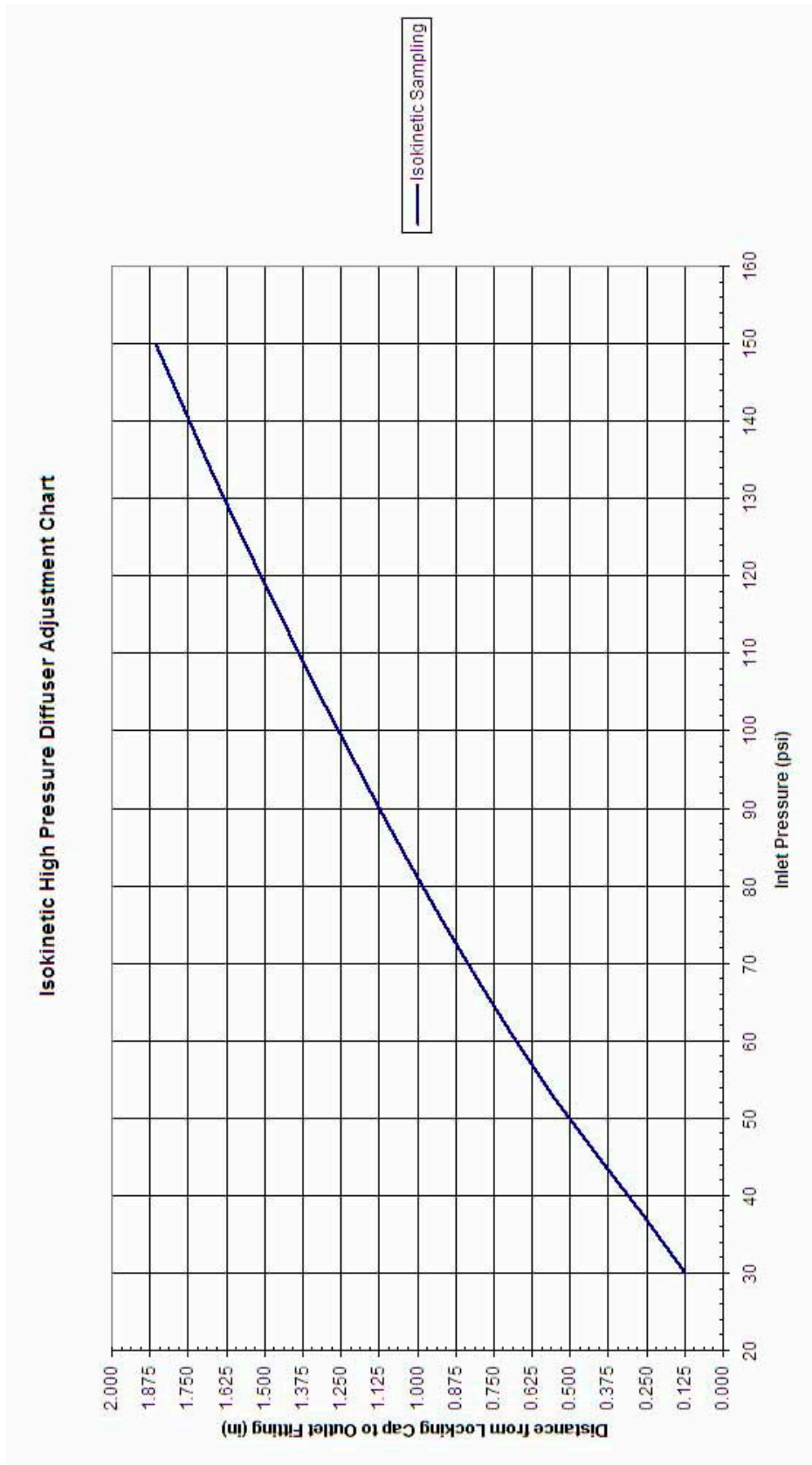

Figure 3-2: English measurements



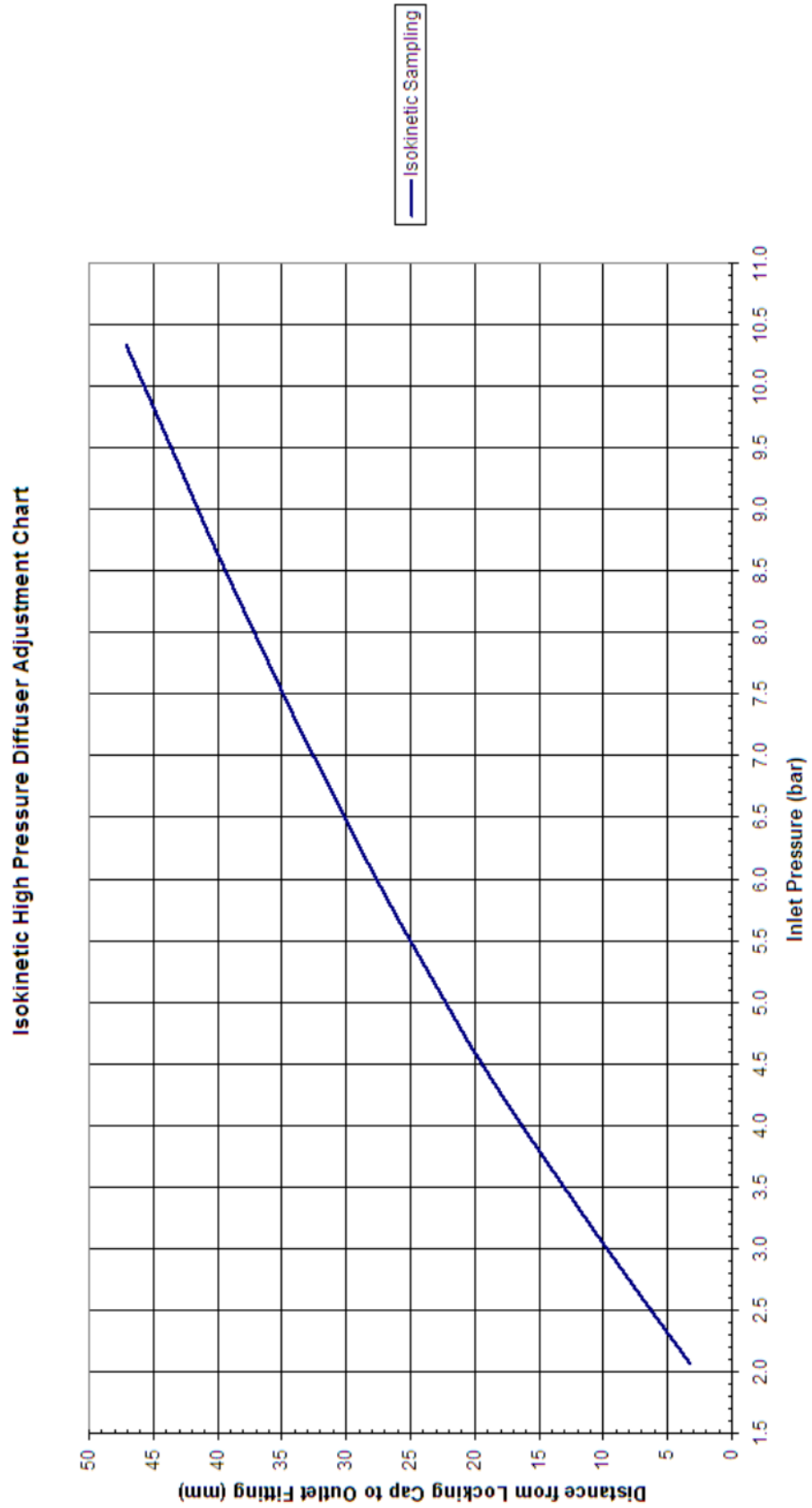

Figure 3-3: Metric Measurements

## Connecting the Diffuser

**Note:** Always use new Gasket Fittings to ensure a good pressure seal.

**Warning:** Do not block or plug the exhaust holes in the Vented version, nor plug the exhaust port on the Ported version of the High Pressure Diffuser. This action will prevent the Diffuser from lowering the input pressure, pressurizing the connected particle counter and possibly causing extensive damage.



Figure 3-4 Vented HPD

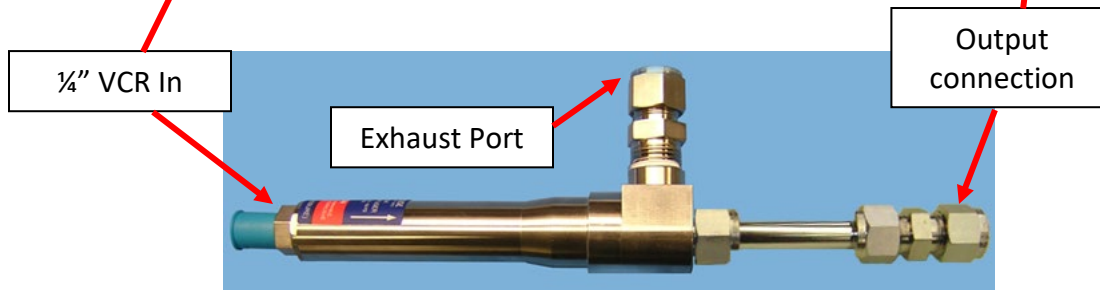

Figure 3-5 Ported HPD

1. Attach a new Gasket Fitting to the  $\frac{1}{4}$ " VCR male connector on the input of the Diffuser.
2. Connect the Diffuser Input to the high pressure supply using a  $\frac{1}{4}$ " VCR female connector. Make the connection finger tight, then use a wrench to tighten another  $45^\circ$ .
3. Connect the correct tubing size, dependent on the Diffuser version, to the output. Insert the tubing into the compression fitting. Make the connection finger tight, then use a wrench to tighten another  $45^\circ$ .
4. For the Ported Diffuser: Connect the Exhaust Port to your exhaust system. Loosen the nut on the Exhaust Port enough to insert the exhaust tubing through the clamping ferrules, then tighten the nut finger tight plus another  $45^\circ$  using a wrench.

## 4 Maintenance

The Isokinetic High Pressure Diffuser may become contaminated with particles, especially if it is used or stored in an uncontrolled environment. If you suspect the Diffuser is contributing to particle counts, it can be disassembled and cleaned.

**NOTE:** Send the Diffuser in to a certified Service Center for disassembly and cleaning. The threads and components have very tight tolerances and can easily be unintentionally damaged.

Before performing any maintenance, refer to Chapter 1, Safety, and become familiar with the information contained therein. Be sure to remove the Diffuser from the High Pressure system before performing maintenance.